

725 Watt Electric Vehicle Li-Ion Charger Data Sheet

Description:

The EVC725 is a 2 stage constant current / constant voltage charger for use in charging Lithium Ion battery systems used in Electric Vehicles.

Features:

- Universal AC Input / Full Range
- 90 – 264 VAC Input
- High Reliability
- Communications via CAN bus
- Efficiency up to 94%
- Over Voltage Protection
- Short Circuit Protection
- Over Temperature Protection
- Waterproof IP65 Enclosure



Model Number	Output Current	Current Range	Voltage Range
EVC-116-725	6A	5.8 – 6.2A	69V – 116V

Specifications:

Input Parameters				
	Min	Typ	Max	Units
Input Voltage Range (Designed to optimum performance at 110 and 220 nominal lines)	90	110	264	VAC
Input Frequency		47 – 63		Hz
Power Factor				
110 VAC Input, Full Load	0.99			
220 VAC Input, Full Load	0.96			
Input Current				A rms
110VAC, Continuous			10	
240VAC, Continuous			5	
Efficiency				
115VAC Full Load		92		
220VAC Full Load		94		

Output Parameters				
	Min	Typ	Max	Units
Output Power	406	612	720	W
Noise & Ripple – Iout 25°C – 20MHz bandwidth			10	% Iout
Turn-on Delay Time – Full Load			3	Sec
Overshoot and Undershoot Response (Power On/Off)			10	%

Specifications:

General Specifications			
Short Circuit Protection	Hiccup Mode Self Recovery when fault is removed		
Over Voltage Protection	Enters Auto recovery mode when output voltage is between 127.8 and 162.7V. The unit will return to normal operation when powered back on.		
Over Temperature Protection	The unit will go into thermal protection as the maximum temperature outside the case exceeds 85±5 °C. The unit will enter hiccup mode and will self-recover when the temperature becomes normal.		
CAN Baud Rate	500Kbps		
MTBF: (MIL-HDBK-217F 25°C)	> 200,000 Hours		
Temperature - Operating	MIN	-23	°C
	MAX	85	
Temperature - Storage	MIN	-40	°C
	MAX	+85	
Relative Humidity	10% - 100%		
Weatherproof	IP65 for Enclosure IP25 for Charger Connector		
Case Size	12.20 x 7.08 x 2.0" 310mm x 180mm x 51mm Anodized Black Finish		
Unit Weight	2.9 kg		
Agency Approval	Designed to meet UL/CSA and TUV		

Electromagnetic Compatibility EMI/EMC	
EMI, RFI	Comply with EN55002 Class A, shall have a minimum of 6dB margin.
Immunity:	
EN61000-3-2	Harmonic Current Emission
EN61000-3-3	Voltage Fluctuations and Flicker
EN61000-4-2	ESD 8kV Air Discharge, 4kV Contact Discharge
EN61000-4-3	Radio-Frequency Electromagnetic Field Susceptibility Test-Rs
EN61000-4-4	Electrical Fast Transient/Burst – EFD
EN61000-4-5	Surge Immunity Test, AC power line: line to line 2kV, line to each 4kV

EN61000-4-6	Conducted Radio Frequency Disturbance
EN61000-4-8	Power Frequency Magnetic Field Test
EN61000-4-11	Voltage Dips

Notes:

(1) Specification is subject to change without notice.

Derating Curves:

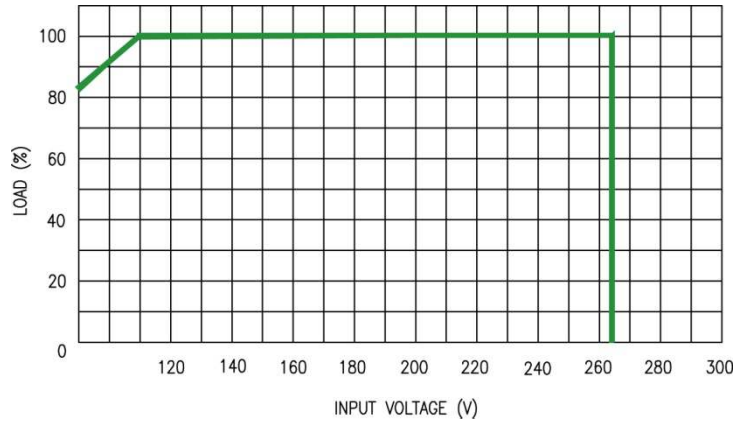
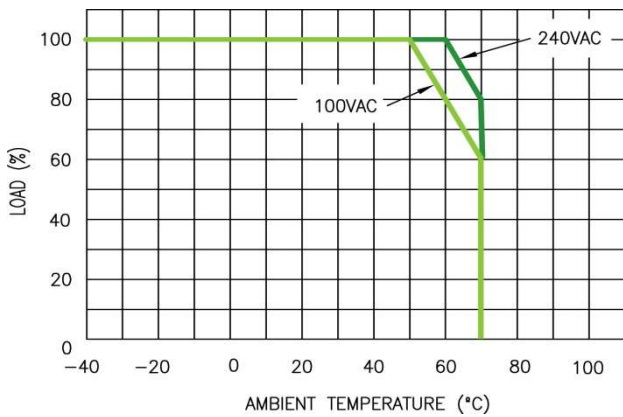

Charging Curve:

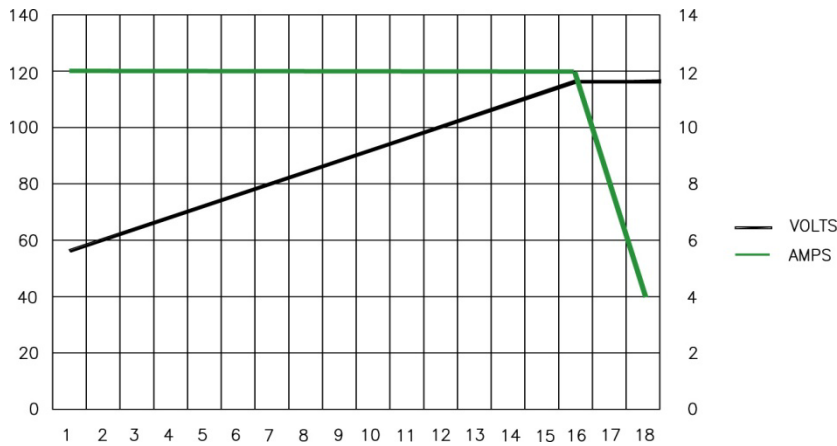

AMPS	VOLTS
6	56
6	60
6	64
6	68
6	72
6	76
6	80
6	84
6	88
6	92
6	96
6	100
6	104
6	108
6	112
6	116
4	116.2
2	116.2

Case Specifications:

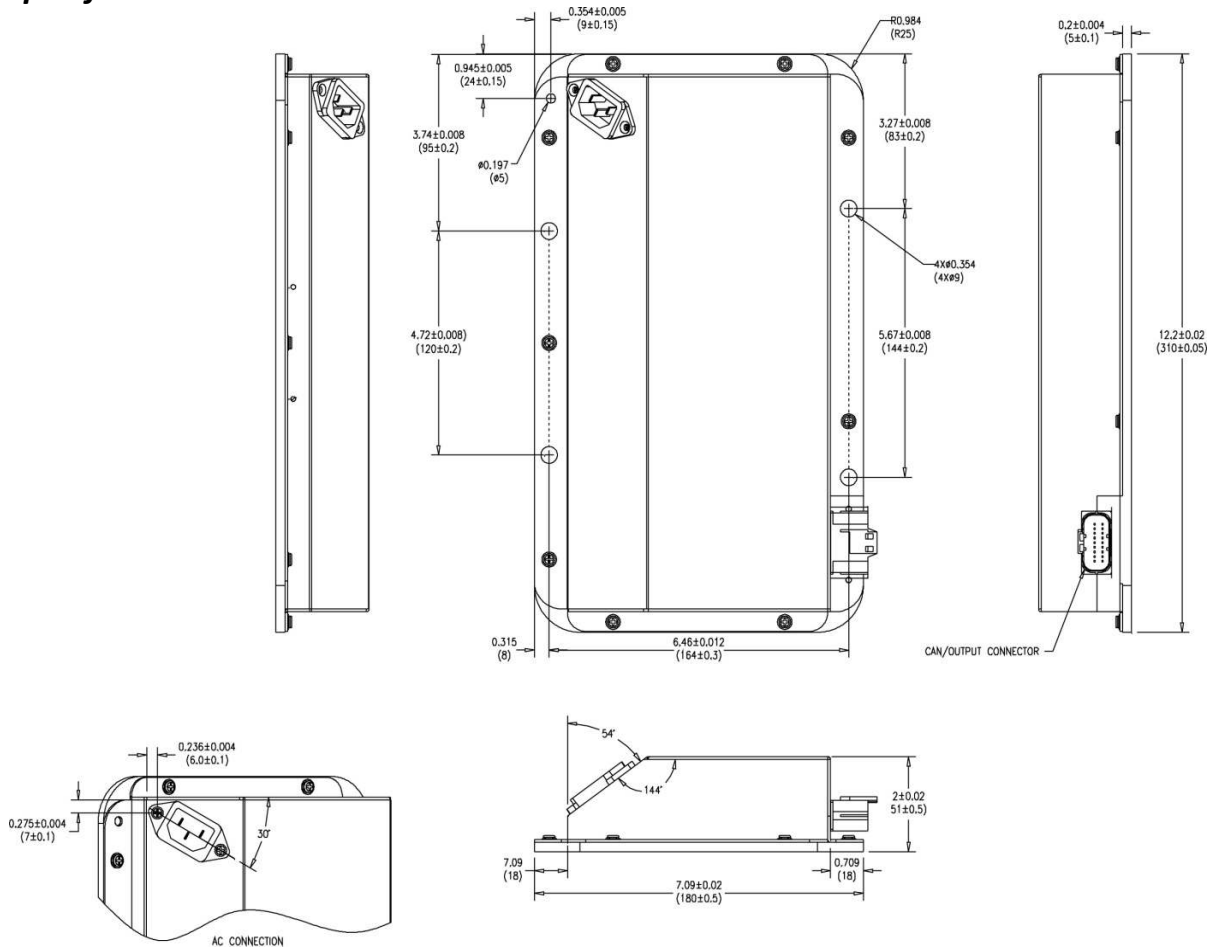

All dimensions are inches

CAN Signal Connector:

Will be JAE MX23A18NF1 present on a PCB connector and shall be mounted to the charger body Pinout, by pin number. Undefined pins are no connection or factory use.

Pin	Function
1	Not Connected
2	Not Connected
3	B- Output
4	CAN-gnd
5	CAN-5V
6	CANL
7	CANH
8	Not Connected
9	B+ Output

Pin	Function
10	B+ Output
11	ob_charger_attached [charger_attached]
12	Charger_en_0 [charger_en_n]
13	Ob_charger_ref_0 [charger_gnd_ref]
14	B- Output
15	Programming gnd
16	Programming bgnd
17	Programming reset
18	Programming vdd