

500 Watt DC/DC Converter EVD Series Data Sheet



Description:

The 500 Watt EVD series is a ruggedized DC-DC converter suitable for electric vehicle, marine, industrial and other applications that draw power from a bank of batteries or other high DC voltages. It is used to supply power to accessories, lights, instruments, etc.

- Fully Isolated
- High Reliability
- High Efficiency at 93%
- Parallel Connection (up to 10X units)
- Over Voltage Protection
- Short Circuit Protection
- Over Temperature Protection
- Input Reverse Polarity Protection
- Enable/Remote On/Off
- Very Low Quiescent Current
- IP66 Enclosure
- RoHS Compliant
- Available with standard Molex or Flying Lead connectors



Model Number	Input Voltage Range	Output Voltage (Max)	Input Amps	Output Amps	Max in Parallel	Connection
EVD-48-500-13	30-65	13.5	18	38	10	Molex 42820 Series
EVD-48-500-13F	30-65	14.2	18	35	10	Flying Lead
EVD-48-500-14	30-65	14.2	18	35	10	Molex 42820 Series
EVD-80-500-13	50-126	13.5	11	38	10	Molex 42820 Series
EVD-80-500-14	50-126	14.2	11	35	10	Molex 42820 Series
EVD-80-500-27	50-130	27.5	11	18.5	10	Molex 42820 Series
EVD-80-500-13F	50-130	13.5	11	38	10	Flying Lead
EVD-80-500-14F	50-126	14.2	11	35	10	Flying Lead
EVD-80-500-27F	50-130	27.5	11	18.5	10	Flying Lead
EVD-80-500-14FP	50-126	14.2	11	35	10	Flying Lead W/Connectors
EVD-80-500-27FP	50-126	27.5	11	18.5	10	Flying Lead W/Connectors

Note 1: For all 48V input products, all input specifications are identical.

Note 2: For 80V input products, some input specifications are different (see individual details).

Note 3: All specifications for the OUTPUT voltages are identical for the standard and "F" options. If ordering the "FP" option, the output specs again are identical: however, there are differences in the Output Over-Current Limit section in Application Notes.

All 48V Input Specifications (EVD-48-500-13/14)

INPUT PARAMETERS				
	Min	Typ	Max	Units
Input Voltage Range	30	48	65	VDC
Input Current @ 30VDC Input and Full Load			18	A
Input Current No Load Vin = 30V, Io = 0 Vin = 65V, Io = 0			100 90	mA
Input Current in Shut Down Mode (Quiescent Current)			30	μA

INPUT UVP/OVP				
	Min	Typ	Max	Units
Input UVLO, Turn Off Io = 0A Io = 38A	24	26	28	VDC
Input ULVO, Turn On Io = 0A Io = 38A	26	28	30	VDC
Input OVLO, Turn Off Io = 0A Io = 38A	67	69	71	VDC
Input OVLO, Turn On Io = 0A Io = 38A	65	67	69	VDC

13V Output Specifications for 48V Inputs (EVD-48-500-13)

OUTPUT PARAMETERS				
	Min	Typ	Max	Units
Output Voltage Vin = 48V, Io = 0-38A	13.2	13.5	13.8	VDC
Output Current			38	A
Load Regulation Vin = 48V, Io = 0-38A			7	%
Line Regulation Vin = 30V-65V, Io = 38A			1	%
Ripple & Noise (20MHz) (3)		100	140	mV (p-p)
Overshoot/Undershoot			5	%
Load Transient Response 13.4V-14.2V, load step 10A-19A, R/S: 0.1A/μS			10	mS
Output Current Protection	42		48	A
Start Up Time @ 25°C, Full Load by Vin @ 25°C, Full Load by Enable			500 500	mS
Rise Time @ 25°C, Full Load			500	mS
Output Voltage Protection		15.6	16	V

14V Output Specifications for 48V Inputs (EVD-48-500-14)

OUTPUT PARAMETERS				
	Min	Typ	Max	Units
Output Voltage Vin = 48V, Io = 0-35A	13.8	14.2	14.6	VDC
Output Current			35	A
Load Regulation Vin = 48V, Io = 0-35A			7	%
Line Regulation Vin = 30V-65V, Io = 35A			1	%
Ripple & Noise (20MHz) (3)		100	140	mV (p-p)
Overshoot/Undershoot			5	%
Load Transient Response 13.9V-14.1V, load step 10A-19A, R/S: 0.1A/μS			10	mS
Output Current Protection	39		45	A
Start Up Time @ 25°C, Full Load by Vin @ 25°C, Full Load by Enable			500 500	mS
Rise Time @ 25°C, Full Load			500	mS
Output Voltage Protection		15.6	16	V

80V Input Specifications for 126V Max Models (EVD-80-500-13/14/14F/14FP/27FP)

INPUT PARAMETERS				
	Min	Typ	Max	Units
Input Voltage Range	50	72	126	VDC
Input Current @ 50VDC Input and Full Load			11	A
Input Current No Load for 13/14V Output Vin = 50V, Io = 0 Vin = 126V, Io = 0			150 100	mA
Input Current No Load for 27V Output Vin = 50V, Io = 0 Vin = 126V, Io = 0			200 150	mA
Input Current in Shut Down Mode (Quiescent Current)			30	μA
INPUT UVP/OVP				
	Min	Typ	Max	Units
Input UVLO, Turn Off Io = 0A Io = 38A	44	46	48	VDC
Input ULVO, Turn On Io = 0A Io = 38A	46	48	50	VDC
Input OVLO, Turn Off Io = 0A Io = 38A	128	130	132	VDC
Input OVLO, Turn On Io = 0A Io = 38A	126	128	130	VDC

80V Input Specifications for 130V Max Models (EVD-80-500-13F/27/27FP)

INPUT PARAMETERS				
	Min	Typ	Max	Units
Input Voltage Range	50	72	130	VDC
Input Current @ 50VDC Input and Full Load			11	A
Input Current No Load for 13V (F) output Vin = 50V, Io = 0 Vin = 126V, Io = 0			150 100	mA
Input Current No Load for 27V outputs Vin = 50V, Io = 0 Vin = 126V, Io = 0			200 150	mA
Input Current in Shut Down Mode (Quiescent Current)			30	μA
INPUT UVP/OVP				
	Min	Typ	Max	Units
Input UVLO, Turn Off Io = 0A Io = 38A	44	46	48	VDC
Input ULVO, Turn On Io = 0A Io = 38A	46	48	50	VDC
Input OVLO, Turn Off Io = 0A Io = 38A	132	134	136	VDC
Input OVLO, Turn On Io = 0A Io = 38A	130	132	134	VDC

13V Output Specifications for 80V Inputs (EVD-80-500-13)

OUTPUT PARAMETERS				
	Min	Typ	Max	Units
Output Voltage Vin = 72V, Io = 0-38A	13.2	13.5	13.8	VDC
Output Current			38	A
Load Regulation Vin = 72V, Io = 0-38A			7	%
Line Regulation Vin = 50V-126V, Io = 38A			1	%
Ripple & Noise (20MHz) (3)		100	140	mV (p-p)
Overshoot/Undershoot			5	%
Load Transient Response 13V-14V, load step 10A-19A, R/S: 0.1A/μS			10	mS
Output Current Protection	43		51	A
Start Up Time @ 25°C, Full Load by Vin @ 25°C, Full Load by Enable			500 500	mS
Rise Time @ 25°C, Full Load			500	mS
Output Voltage Protection		15.6	16	V

14V Output Specifications for 80V Inputs (EVD-80-500-14)

OUTPUT PARAMETERS				
	Min	Typ	Max	Units
Output Voltage Vin = 72V, Io = 0-35A	13.8	14.2	14.6	VDC
Output Current			35	A
Load Regulation Vin = 72V, Io = 0-35A			7	%
Line Regulation Vin = 50V-126V, Io = 35A			1	%
Ripple & Noise (20MHz) (3)		100	140	mV (p-p)
Overshoot/Undershoot			5	%
Load Transient Response 13.5V-14.9V, load step 5A-9A, R/S: 0.1A/μS			10	mS
Output Current Protection	43		51	A
Start Up Time @ 25°C, Full Load by Vin @ 25°C, Full Load by Enable			500 500	mS
Rise Time @ 25°C, Full Load			500	mS
Output Voltage Protection		15.6	16	V

27V Output Specifications for 80V Inputs (EVD-80-500-27)

OUTPUT PARAMETERS				
	Min	Typ	Max	Units
Output Voltage Vin = 72V, Io = 0-18.5A	27	27.5	28	VDC
Output Current			18.5	A
Load Regulation Vin = 72V, Io = 0-18.5A			7	%
Line Regulation Vin = 50V-126V, Io = 18.5A			1	%
Ripple & Noise (20MHz) (3)		200	280	mV (p-p)
Overshoot/Undershoot			5	%
Load Transient Response 27V-28.2V, load step 5A-9A, R/S: 0.1A/μS			10	mS
Output Current Protection	23		27	A
Start Up Time @ 25°C, Full Load by Vin @ 25°C, Full Load by Enable			500 500	mS
Rise Time @ 25°C, Full Load			500	mS
Output Voltage Protection		30	31	V

General Specifications for all 500W DC/DC Converters:

Remote On/Off				
Converter On	Enable (ON/OFF) connected to +Vin. *Activates from 3 to 6 VDC, referenced to -Vin up to +Vin MAX.			
General Specification				
	Min	Typ	Max	Units
Capacitive Load			5000	μF
Isolation Voltages (60 Seconds)				
Input to Output	1500			VAC
Output to Case	500			
Isolation Resistance (500 VDC)	10			Mohms
Operating Temperature (Ambient)	-40		+75	°C
Storage Temperature	-40		+85	°C
Baseplate Temperature			+95	°C
Humidity	0		90	%
MTBF Mil-HDBK-217F @ 25°C Ground Benign	150			kHours
Cooling	Baseplate temperature cannot exceed specified maximum, under all operating conditions in application			
Case Size	7.48 x 2.99 x 1.71 inches 190.0 x 76.0 x 43.5 mm			
Case Material	Metal			
Weight	1.25 kg			
Agency Approvals:	Designed to meet IEC, UL, CSA			

Application Notes:

Over Voltage Protection:

The power converter includes an internal output over voltage protection (OVP) circuit, which monitors the voltage on the output terminals. If this voltage exceeds the OVP set point, the converter will shut down and then restart after a fixed delay time (hiccup mode).

Over Temperature Protection:

The over-temperature protection consists of circuitry that provides protection from thermal damage. If the temperature exceeds the preset temperature threshold, the converter will shut down, and all components will not exceed their absolute maximum temperature ratings. The converter will restart after the baseplate temperature is below 85°C.

Output Over-Current Limit and Short Circuit Protection:

The converters include internal over-current protection (OCP) and short circuit protection (SCP) circuits. The response of the SCP circuit is much faster than that of the OCP circuit. Slow increase of the output current will let the converter enter OCP protection when the current exceeds the OCP set point, while the fast increase of the output current will let the converter enter SCP when the currents exceeds the SCP set point.

-13: The OCP is designed with constant current mode with trigger point of typical $1.15 \cdot I_{o_nom}$. when the output current greater than the trigger point, the output voltage will go to near zero and the output current will keep at typical $1.15 \cdot I_{o_nom}$ after a short delay of 20ms.

The SCP is also designed with constant current mode with trigger point of typical $1.15 \cdot I_{o_nom}$. When SCP events happen, like suddenly short the output, the module will turn off first and then enter into constant current mode.

Both OCP and SCP protection can be auto-recovered when the protection is removed.

The module can charge Aux. battery attached on the output with a constant current of $1.15 \cdot I_{o_nom}$ typical, from 9V to 13.8V. Care should be taken if the Aux. battery nominal sink current is less than $1.15 \cdot I_{o_nom}$. For this condition, an additional charging circuit should be added on the system side.

-14: The OCP is designed with constant current mode with trigger point of typical $1.15 \cdot I_{o_nom}$. when the output current greater than the trigger point, the output voltage will go to near zero and the output current will keep at typical $1.35 \cdot I_{o_nom}$ after a short delay of 20ms.

The SCP is also designed with constant current mode with trigger point of typical $1.15 \cdot I_{o_nom}$. When SCP events happen, like suddenly short the output, the module will turn off first and then enter into constant current mode.

Both OCP and SCP protection can be auto-recovered when the protection is removed.

The module can charge Aux. battery attached on the output with a constant current of $1.15 \cdot I_{o_nom}$ typical, from 9V to 14.6V. Care should be taken if the Aux. battery nominal sink current is less than $1.15 \cdot I_{o_nom}$. For this condition, an additional charging circuit should be added on the system side.

FP Models -14FP and 27FP: The OCP is designed with constant current mode with trigger point of typical $1.35 \cdot I_{o_nom}$. when the output current greater than the trigger point, the output voltage will go to near zero and the output current will keep at typical $1.35 \cdot I_{o_nom}$ after a short delay of 20ms.

The SCP is also designed with constant current mode with trigger point of typical $1.35 \cdot I_{o_nom}$. When SCP events happen, like suddenly short the output, the module will turn off first and then enter into constant current mode.

Both OCP and SCP protection can be auto-recovered when the protection is removed.

The module can charge Aux. battery attached on the output with a constant current of $1.35 \cdot I_{o_nom}$ typical, from 9V to 14.6V. Care should be taken if the Aux. battery nominal sink current is less than $1.35 \cdot I_{o_nom}$. For this condition, an additional charging circuit should be added on the system side.

Output Over-Current Limit, Short Circuit Protection and when an Auxiliary Battery is connected:

Care should be taken if the DC-DC converter is used with an Auxiliary battery connected on the output. If the battery's recommended safe charging or sink current is less than $1.15 \cdot I_{o_nom}$ for the -13 or $1.15 \cdot I_{o_nom}$ for the -14 DC-DC converter, damage to the battery may result. For this condition where controlled lower current is needed to charge a battery, additional charging circuitry should be added in the customer's system or application side.

Input Reverse Voltage Protection:

The reverse standoff voltage shall be no more than -75VDC for the EVD-48 series models.

The reverse standoff voltage shall be no more than -126VDC for the EVD-80 series models.

Remote On/Off:

The converter has Enable control function. This Enable Pin is designed on the input side of the converter, the converter will turn on when the applied voltage is greater than 6V refer to the VIN-, and turn off when the Enable PIN connected to VIN- or floating. A direct method to turn the converter on is connecting the Enable Pin to VIN+.

Thermal Condition:

The converter should be mounted on a base plate with thermal grease, and the maximum base plate temperature is suggested to be controlled to within 85°C.

Recommended Parallel Connections:

The module supports parallel operation. Modules are suggested to connect in parallel in the following configuration. The impedance of the cables connecting the units should be within 5% of each other.

During parallel operation, all units should be energized and de-energized together to prevent abnormal operation. The modules can support 5000W with ten modules paralleling.

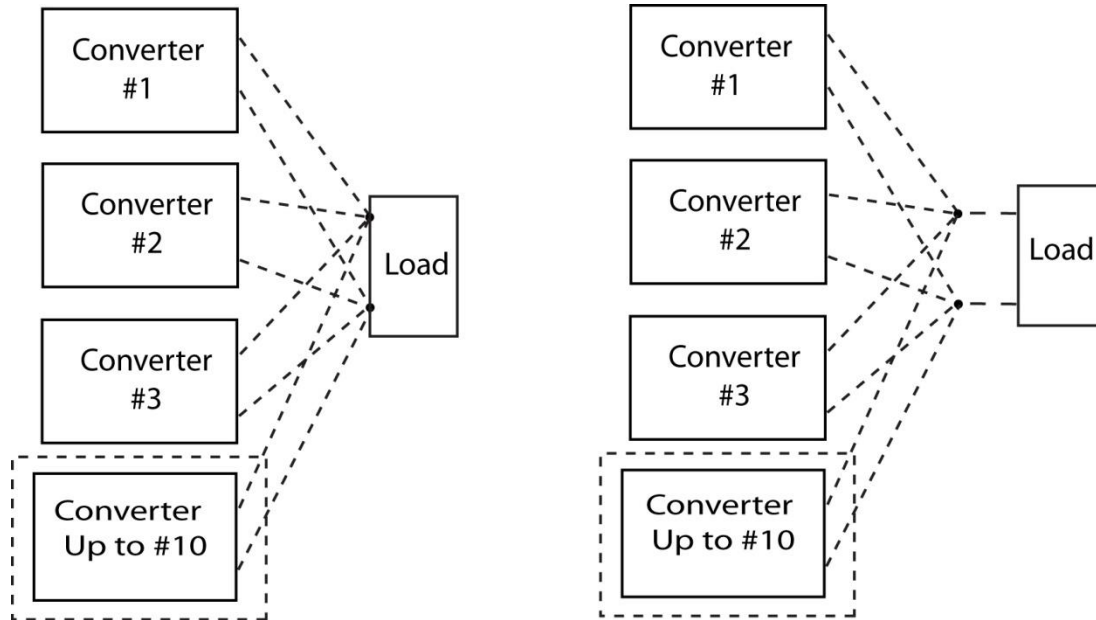

Specification Notes:

- (1) All specifications are stated at 25°C ambient and typical input line.
- (2) Ingress protection to IP66, excluding connectors.
- (3) Output terminated with 10µF aluminum capacitor and 0.1µF MLCC.
- (4) Factory Set-point is Typical Voltage on table ±1.5% @ half load.
- (5) Vibration to withstand 8G in x, y, and z axis from 0 to 200 Hz for 1 minute.
- (6) Units are not designed to be hot-swapped. Hot swapping units while energized will cause damage.
- (7) Specification is subject to change without notice.

Case Specifications for Standard Terminal Pins (EVD-80-500-13 or -14 or -27):

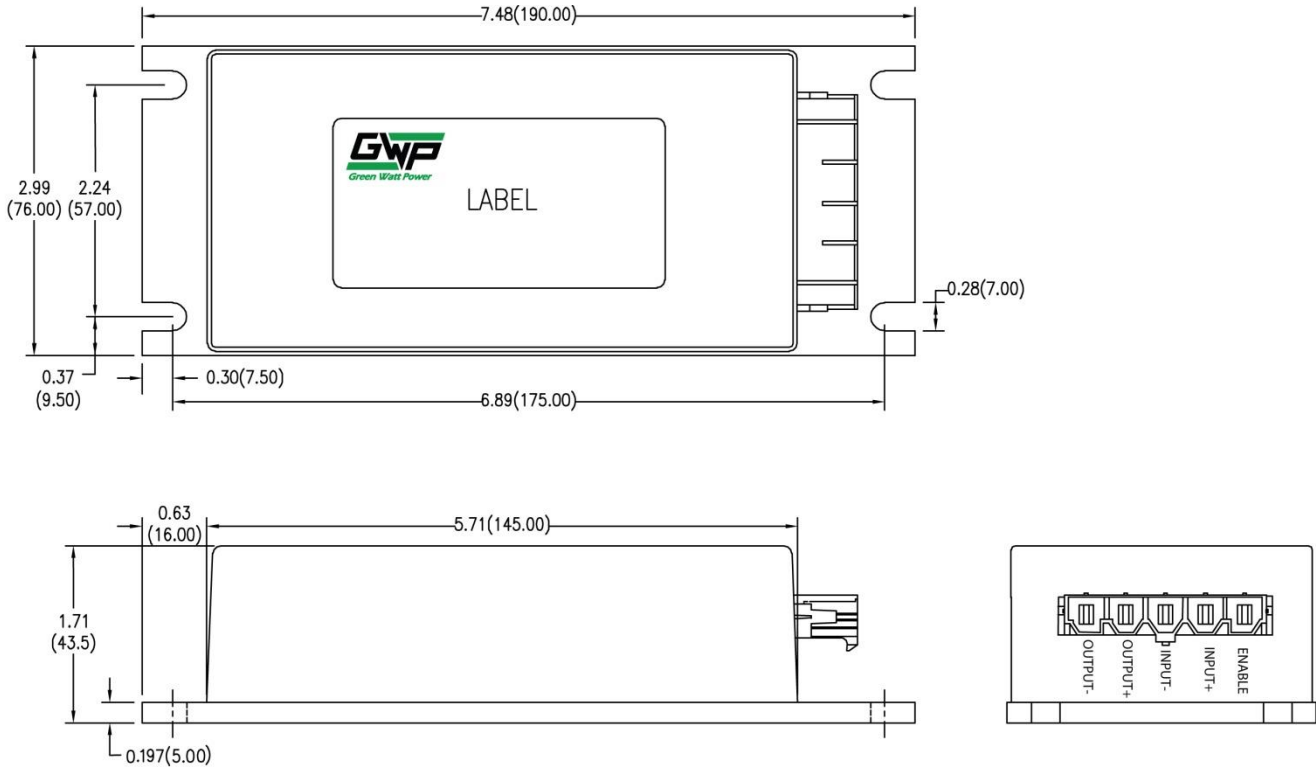

All dimensions are inches (mm)
Tolerance ± 0.01 (0.254mm) unless otherwise noted.

***Notes:**

1. Connector is Molex 42820 Series. Mating connector is Molex 42816-0512 with terminal pins 42815-0114.
2. Output is enabled when enable wire 3 to 6VDC or higher referenced to the -Vin wire. If enable feature is not required enable wire should be connected to +Vin wire.

Case Specifications for Flying Lead Outputs (EVD-80-500-13F or -14F or -27F) or (EVD-48-500-13F):

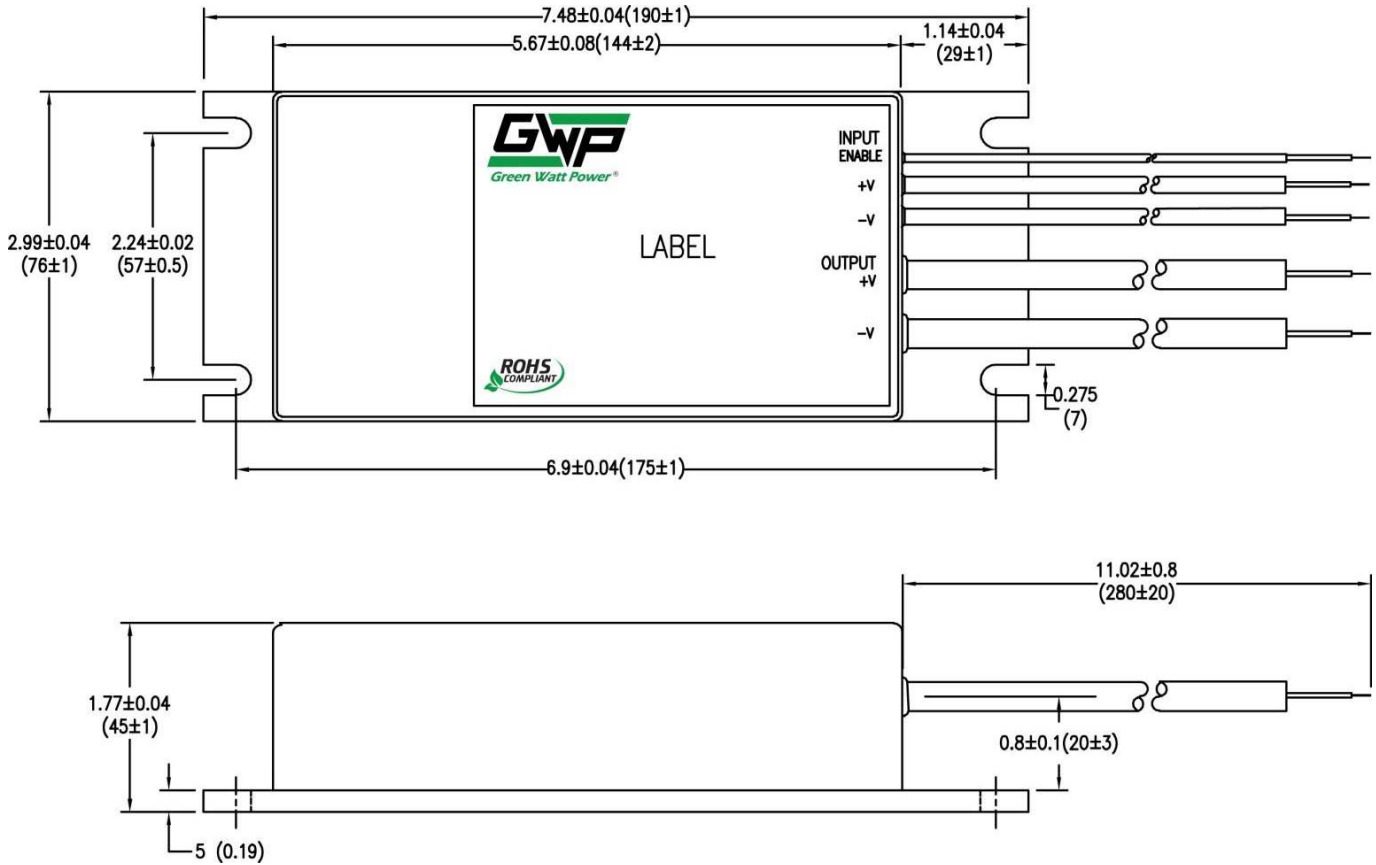

All dimensions are inches (mm)
Tolerance ±0.01 (0.254mm) unless otherwise noted.

*Notes:

1. Output is enabled when enable wire 3 to 6VDC or higher referenced to the -Vin wire. If enable feature is not required enable wire should be connected to +Vin wire.

INPUT FUNCTION	COLOR	-13F / -14F WIRE SIZE	-27F WIRE SIZE
V+	Brown	16 AWG	16 AWG
V-	Blue	16 AWG	16 AWG
Enable	Yellow	18 AWG	18 AWG

OUTPUT FUNCTION	COLOR	-13F / -14F WIRE SIZE	-27F WIRE SIZE
V+	Red	10 AWG	14 AWG
V-	Black	10 AWG	14 AWG

Case Specifications for Flying Lead Outputs with Connectors (EVD-80-500-14FP):

All dimensions are inches (mm). Tolerance ± 0.01 (0.254mm) unless otherwise noted.

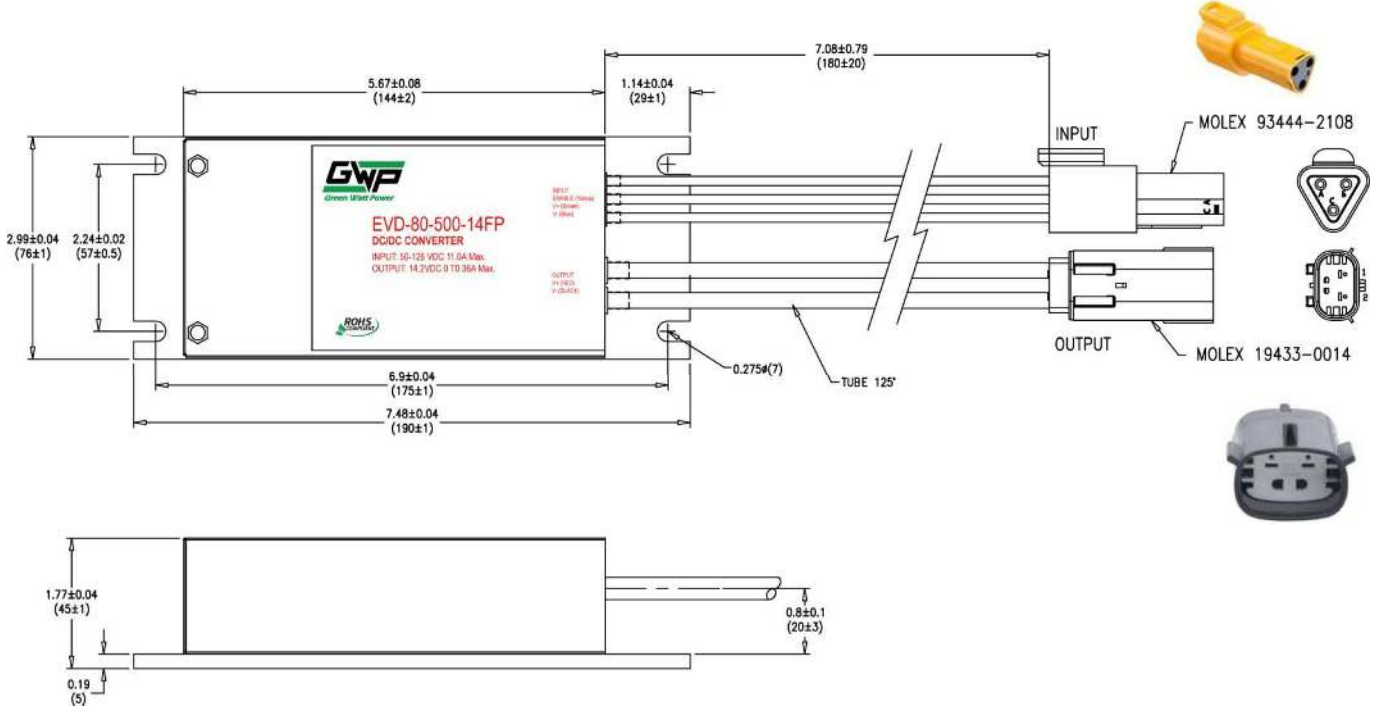

***Notes:**

1. Output is enabled when enable wire 3 to 6VDC or higher referenced to the -Vin wire. If enable feature is not required enable wire should be connected to +Vin wire.

INPUT	FUNCTION	COLOR	WIRE TYPE	WIRE SIZE	CONNECTOR	TERMINAL
A	Enable	Yellow	Alphawire EcoWire Plus 300V	18 AWG	Molex 93444-2108 93447-2003 (Wedglock)	84524-0004
B	V+	Brown	Alphawire EcoWire Plus 300V	16 AWG		84524-0004
C	V-	Blue	Alphawire EcoWire Plus 300V	16 AWG		84524-0004

INPUT	FUNCTION	COLOR	WIRE TYPE	WIRE SIZE	CONNECTOR	TERMINAL
1	V-	Black	SAE J1128	10 AWG	Molex 19433-0014	01943100001
2	V+	Red	SAE J1128	10 AWG		01943100001

Case Specifications for Flying Lead Outputs with Connectors (EVD-80-500-27FP):

All dimensions are inches (mm). Tolerance ± 0.01 (0.254mm) unless otherwise noted.

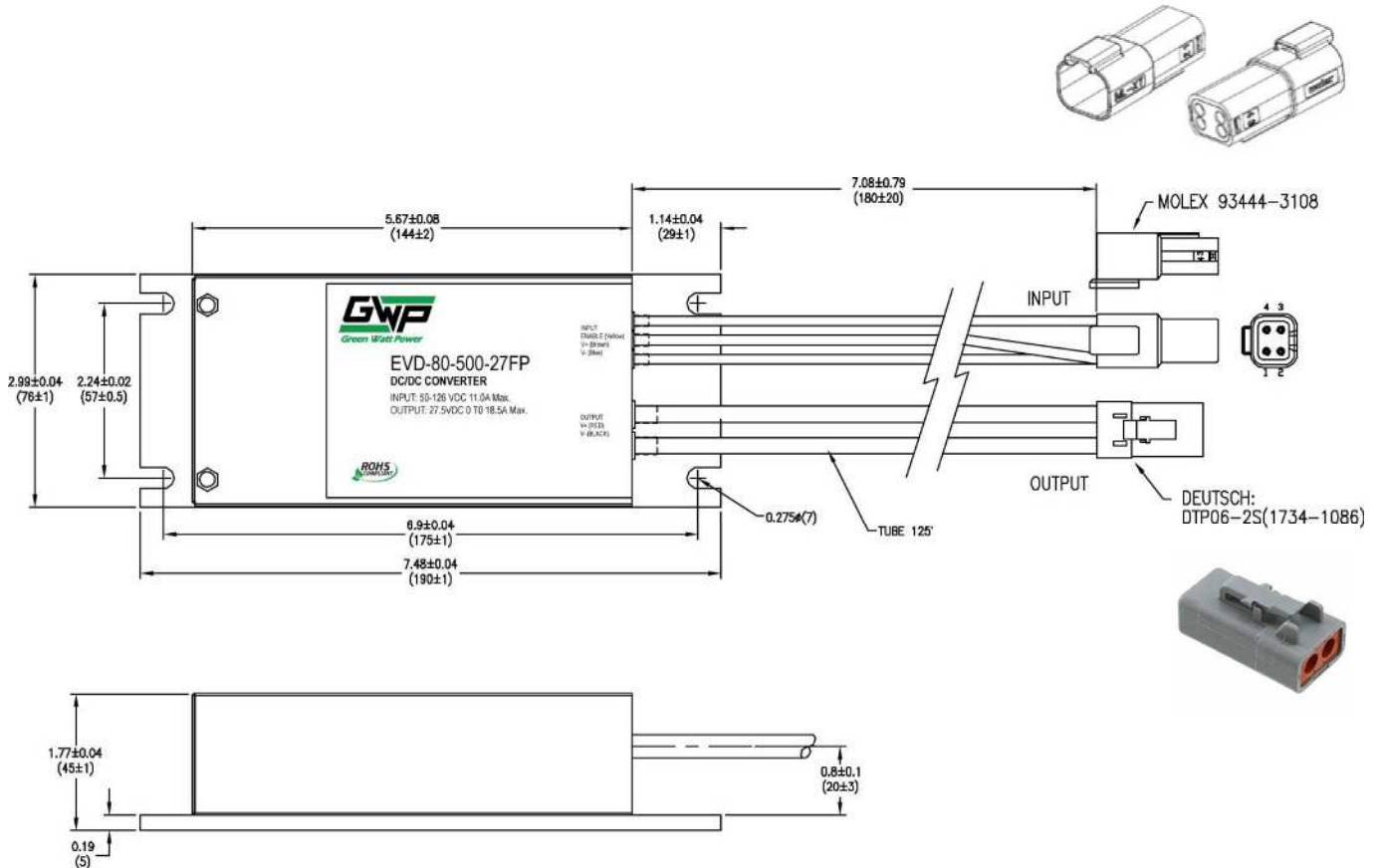

INPUT	FUNCTION	COLOR	WIRE TYPE	WIRE SIZE	CONNECTOR	TERMINAL
1	Enable	Yellow	Alphawire EcoWire Plus 300V	18 AWG	Molex 93444-3108 93447-3003 (Wedglock)	84524-0004
2	V+	Brown	Alphawire EcoWire Plus 300V	16 AWG		84524-0004
3	V-	Blue	Alphawire EcoWire Plus 300V	16 AWG		84524-0004
4	Not Used	Not Used	Not Used	Not Used		93494-1000

INPUT	FUNCTION	COLOR	WIRE TYPE	WIRE SIZE	CONNECTOR	TERMINAL
1	V-	Black	SAE J1128	10 AWG	Deutsch DTP06-2S (1734-1086)	1062-12-0166
2	V+	Red	SAE J1128	10 AWG		1062-12-0166